

KLAUS TEUBER

# CATAN<sup>®</sup>

THE GAME

**ZIP!**  
EDITION



## Tile Holder and Box Assembly

© 2026 CATAN GmbH – CATAN, the CATAN Brand Logo, the “CATAN Sun,” and the CATAN Hex Icon are trademark properties of CATAN GmbH (catan.com). All rights reserved.

Lower tray

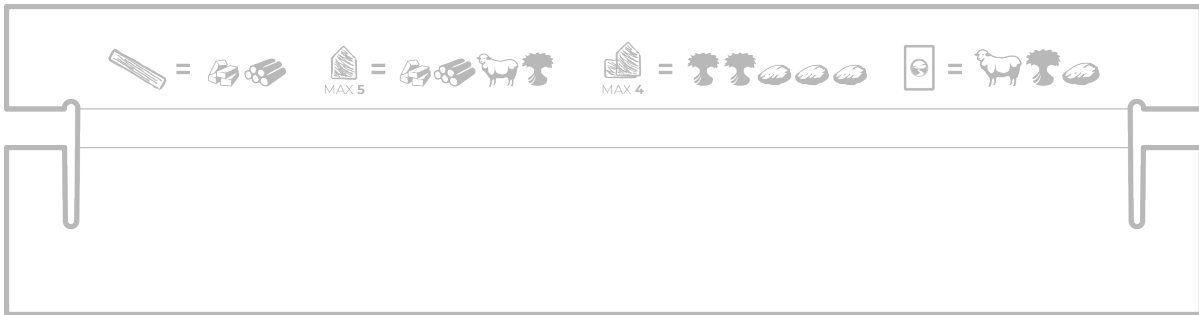

Upper tray

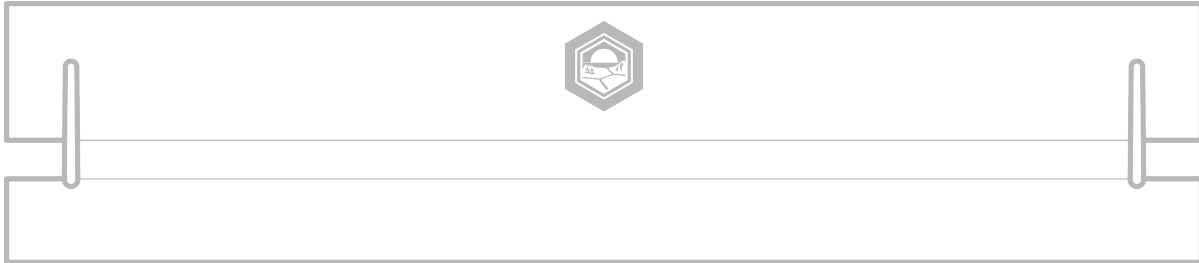

**TRAYS**

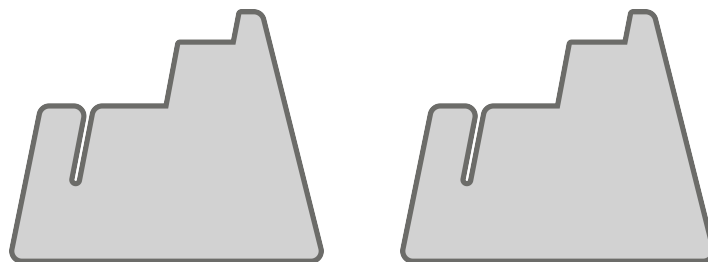

**LEGS**



1

Tile Holder



Each tile holder is made up of 2 trays and 2 leg pieces.  
Fold each tray toward the center to form a U-shape.

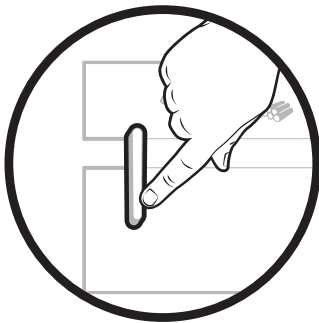
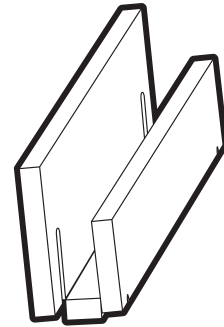
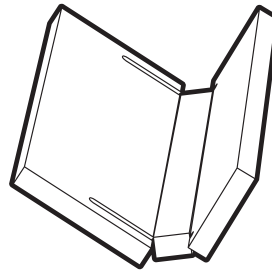
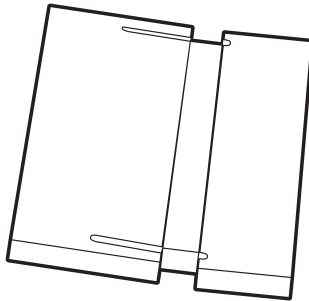

Make sure you have punched  
out the slot pieces that go from  
back of the tray to the  
bottom of the tray.



## 2 Tile Holder



Slide the **Lower tray** onto one of the leg pieces so that the front of the tray sits in the slot of the leg and the back of the tray fits over the lower "shelf" of the leg piece.

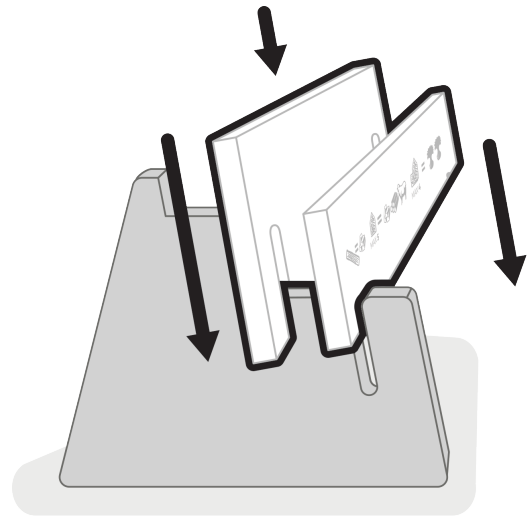

---

Repeat this action with the other leg piece.

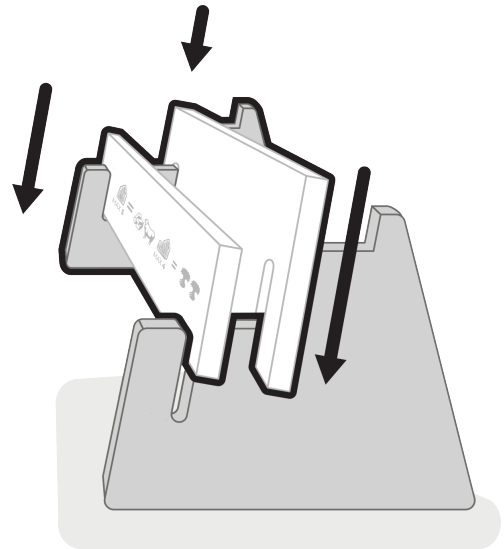

### 3 Tile Holder

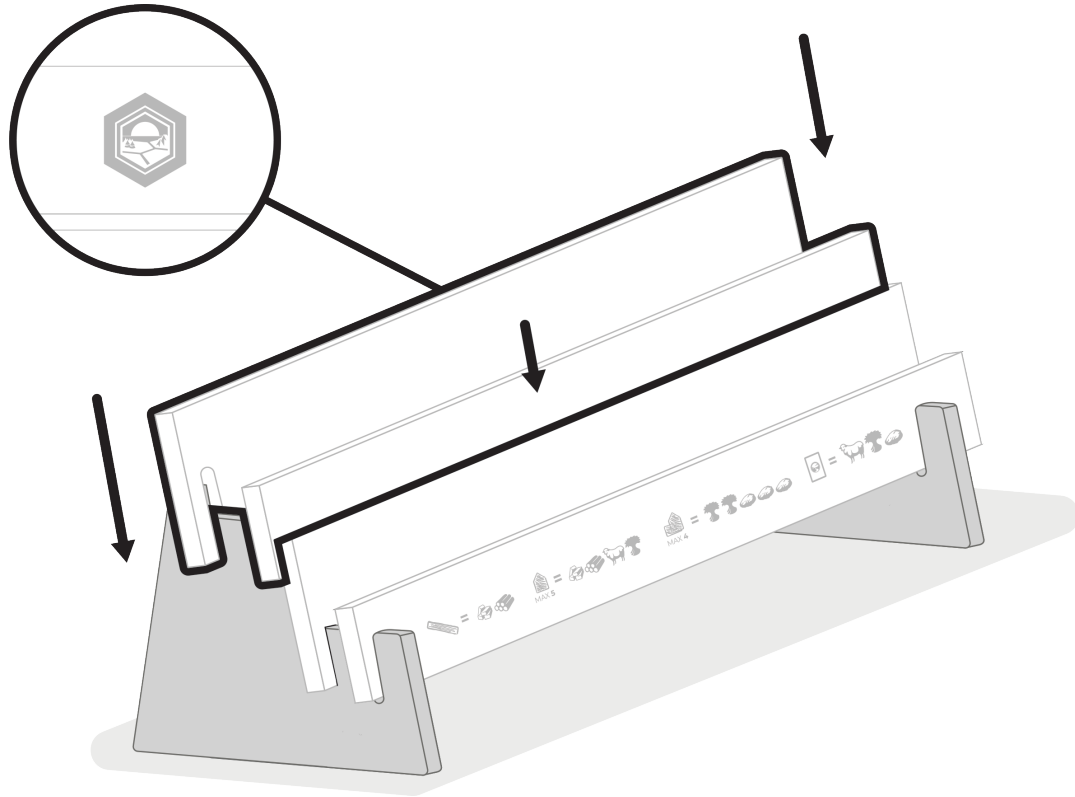

Slide the **Upper tray** onto both leg pieces behind the **Lower tray**. The front of the **Upper tray** rests on the lower "shelf" of the leg pieces, and the back of the tray slots over the top "shelf."



# 1

Box

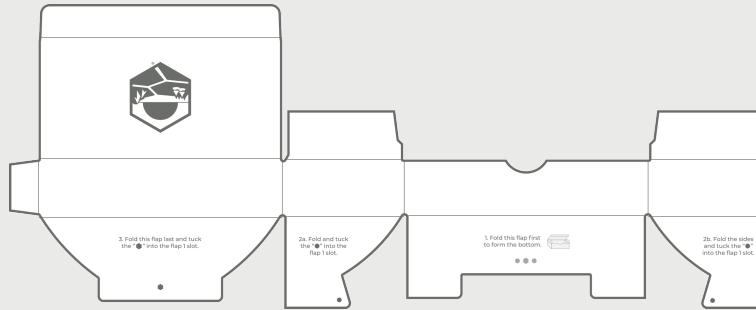
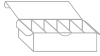

Follow the assembly instructions printed on the bottom flaps of the large yellow box. Then follow the same formula to assemble the smaller yellow boxes.

